

# LE1110 20" MANHOLE ASSEMBLY

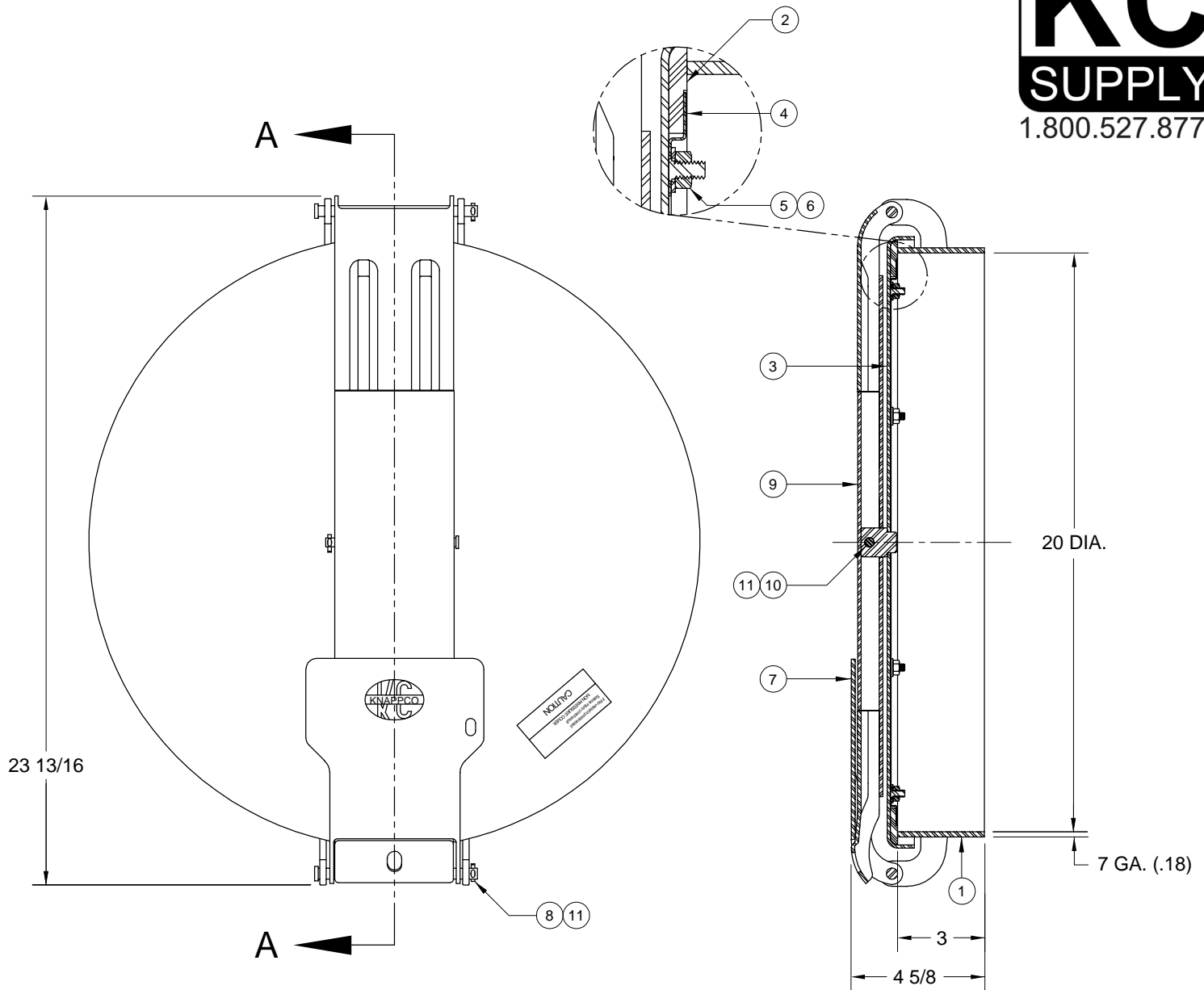

**SECTION A-A**

ITEM	PART NUMBER	DESCRIPTION	QTY.
1	3537	WELD RING ASSY (STEEL)	1
2	1026	GASKET (BUNA)	1
3	2364	COVER WELDMENT (STEEL)	1
4	1027	GASKET RETAINER (STEEL)	1
5	1059	HEX NUT (PLATED)	6
6	1036	WASHER (PLATED)	6
7	1125	LATCH (STEEL)	1
8	2106	CLEVIS PIN (PLATED)	2
9	2365	STRONGBACK ASSY. (STEEL)	1

ITEM	PART NUMBER	DESCRIPTION	QTY.
10	2658	CLEVIS PIN (PLATED)	1
11	1045	COTTER PIN (PLATED)	3

**ALTERNATE SEALING MEDIA**

PART NUMBER	DESCRIPTION
1432	GASKET (WHITE NEOPRENE)
2726	GASKET (HIGH TEMP.)
3622	GASKET (EPDM)
2551 / 1026	GASKET (TEFLON ENVELOPE)
2573	GASKET (VITON)

**KC Supply Co Inc**



[www.kcsupply.com](http://www.kcsupply.com)

PO Box 412196  
Kansas City, MO 64141

Phone: 800.527.8775  
Fax: 816.753.0444