

KG1110 20" MANHOLE ASSEMBLY

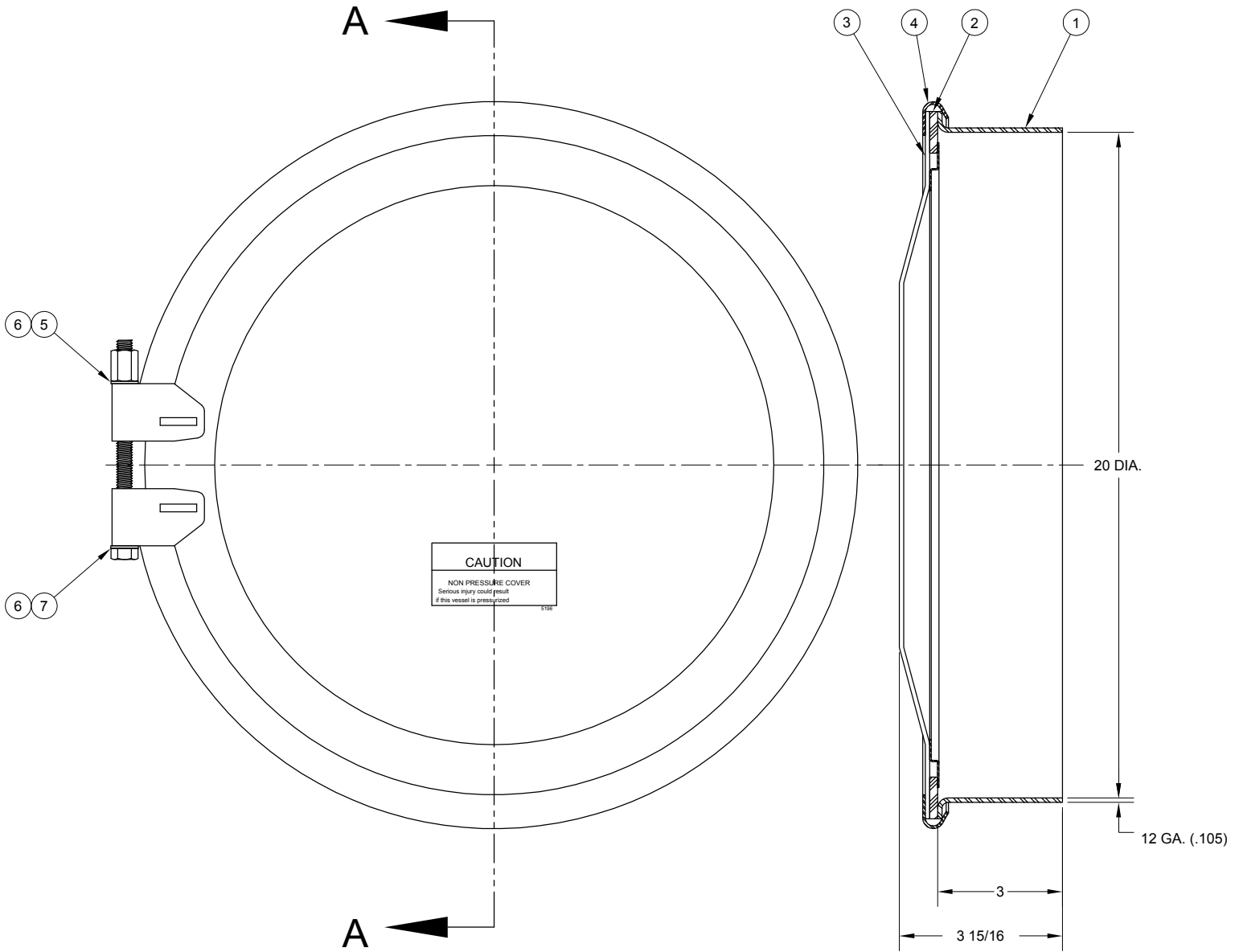

SECTION A-A

ITEM	PART NUMBER	DESCRIPTION	QTY.
1	1175	WELD RING (STEEL)	1
2	1181	GASKET (BUNA)	1
3	1277	COVER WELDMENT (STEEL)	1
4	1177	CLAMP RING ASSY. (STEEL)	1
5	5009	HEX NUT (BRASS)	1
6	1113	WASHER (PLATED)	2

ITEM	PART NUMBER	DESCRIPTION	QTY.
7	1110	HEX CAP SCREW (PLATED)	1

ALTERNATE SEALING MEDIA

PART NUMBER	DESCRIPTION
4128	GASKET (WHITE NEOPRENE)
2570	GASKET (HIGH TEMP.)

