

MJ1110 20" MANHOLE ASSEMBLY

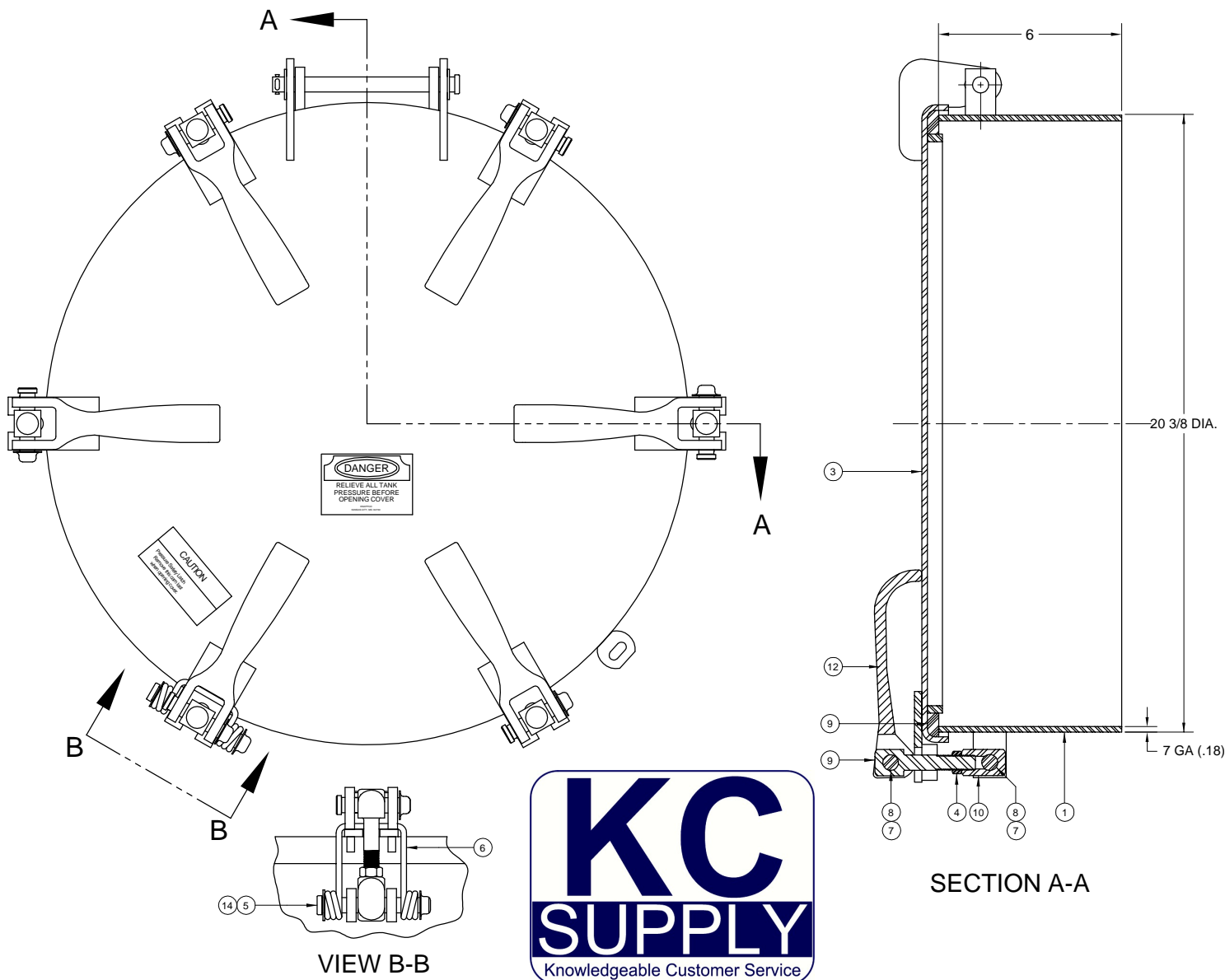

ITEM	PART NUMBER	DESCRIPTION	QTY.
1	1006	WELD RING ASSY (STEEL)	1
2	4683	GASKET (BUNA)	1
3	4734	COVER WELDMENT (STEEL)	1
4	1016	JAM NUT (PLATED) ¹	6
5	1046	CLEVIS PIN (PLATED)	1
6	1019	SAFETY CATCH (STEEL)	1
7	1020	PAL NUT (PLATED) ¹	12
8	3952	CLEVIS PIN (PLATED) ¹	11
9	3950	STUD (PLATED) ¹	6
10	1012	CONNECTOR (PLATED) ¹	6
11	1045	COTTER PIN (PLATED)	1
12	1013	CAM LEVER (STEEL) ¹	6

ITEM	PART NUMBER	DESCRIPTION	QTY.
13	1042	CLEVIS PIN (PLATED)	1
14	1043	WASHER (PLATED)	3

ALTERNATE SEALING MEDIA / CAM ASSEMBLIES

PART NUMBER	DESCRIPTION
5354	GASKET (WHITE NEOPRENE)
5648	GASKET (EPDM)
5221	GASKET (SILICONE)
2567	GASKET (TEFLON ENVELOPE)
5875	GASKET (HIGH TEMP)
1836	CAM ASSEMBLY KIT (STEEL)
1837	CAM ASSEMBLY (PLATED)

1 - Included in 1836

