

KF1110 16" MANHOLE ASSEMBLY

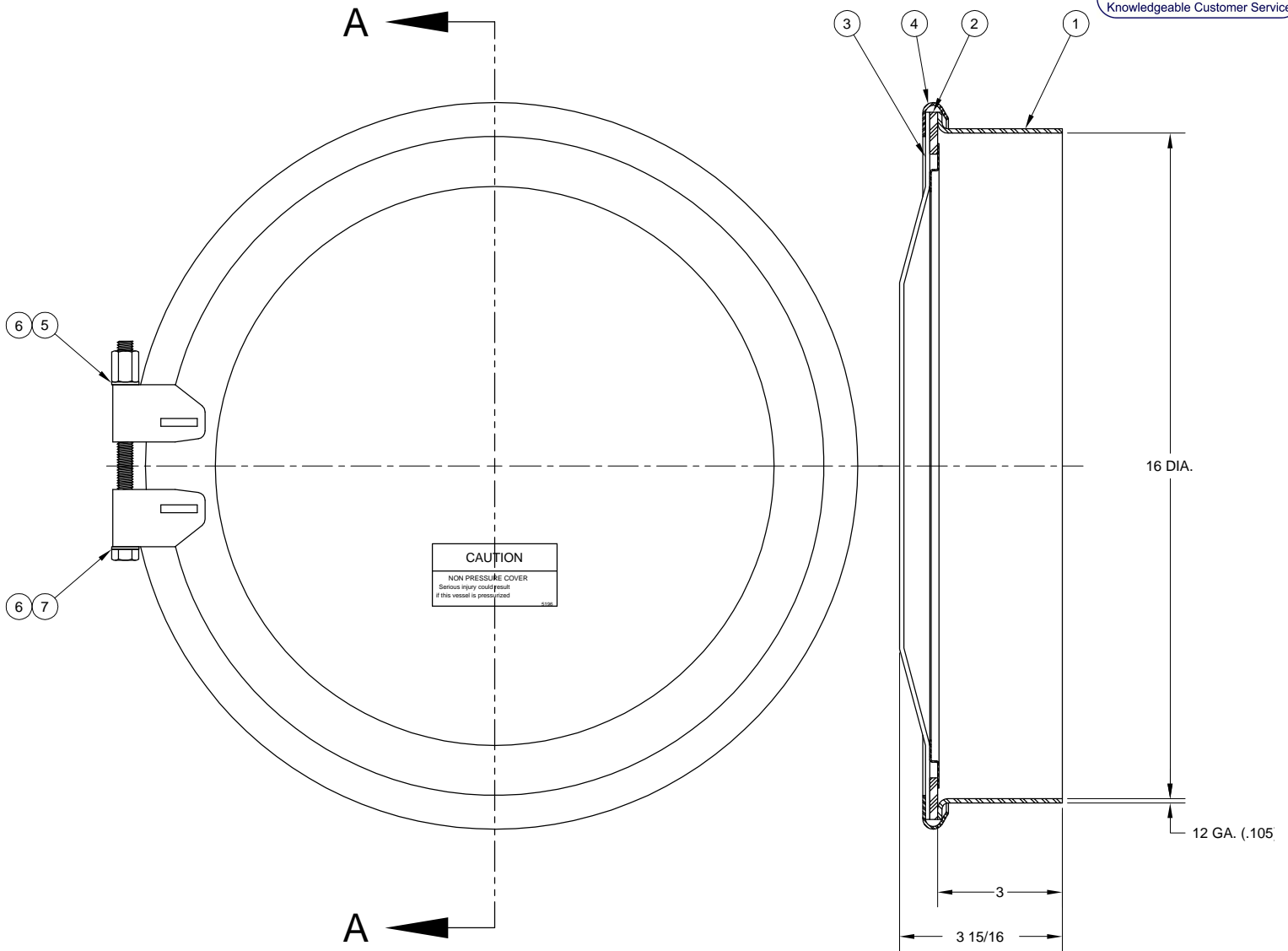

SECTION A-A

ITEM	PART NUMBER	DESCRIPTION	QTY.
1	1089	WELD RING (STEEL)	1
2	1106	GASKET (BUNA)	1
3	1266	COVER WELDMENT (STEEL)	1
4	1107	CLAMP RING ASSY. (STEEL)	1
5	5009	HEX NUT (BRASS)	1
6	1113	WASHER (PLATED)	2
7	1110	HEX CAP SCREW (PLATED)	1

ALTERNATE SEALING MEDIA

PART NUMBER	DESCRIPTION
2558	GASKET (WHITE NEOPRENE)
1377	GASKET (HIGH TEMP.)
4686	GASKET (SILICONE)
4821	GASKET (TEFLON ENVELOPE)
4612	GASKET (EPDM)

